



Vx Aviation™

1160 Yew Ave

Blaine, WA 98230-9222

www.vx-aviation.com

Avismo™ Series Specification and Application Guide

AMX-1A Audio Bus for Sigtronics SPA-400 and Sport-200 Intercom Systems

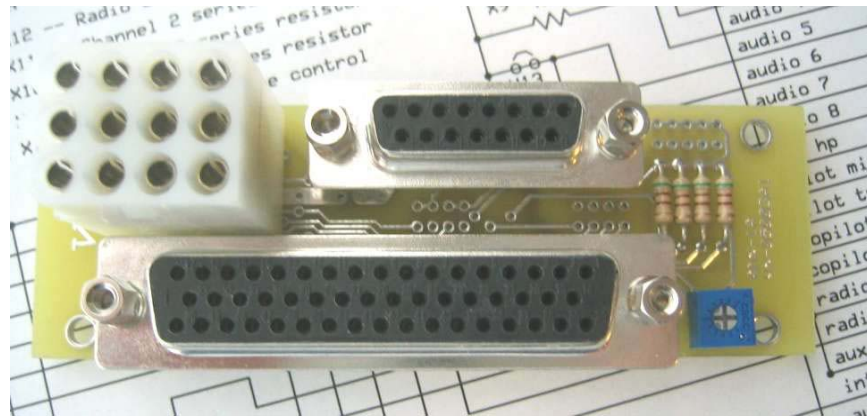

Figure 1-1. AMX-1A Assembly

1. Features

- ❑ Simplifies the wiring of shielded audio cables to Sigtronics SPA-400 and Sport-200 intercom systems.
- ❑ Replaces complicated hand-wiring and 'forest of tabs' connections with simple to use crimp-and-poke D-Subminiature connectors.
- ❑ Provides multiple common ground pins per signal to facilitate shield and signal ground wiring.
- ❑ 12-pin box connector allows direct connection to the existing intercom cable.
- ❑ 50-pin D-Sub connector allows complete wiring of avionics, headphones, microphones, auxiliary audio and push-to-transmit and push-to-intercom key switches.
- ❑ Optional 15-pin D-Sub connector simplifies audio connections for removable panels.
- ❑ Supports ten audio sources directly and provides on-board impedance matching resistors for four channels and a variable resistor (volume control) for one channel.
- ❑ Small footprint of 3.8" x 1.25" (96.5 x 32 mm). May be mounted to airframe or directly to intercom case (simple case modification required).

2. Description

The AMX-1A is an audio bus expansion device that simplifies the connection of shielded audio wiring to Sigtronics SPA-400 and Sport-200 intercoms. It adapts the 12-pin intercom box connector to a 50-pin D-Sub connector for local panel wiring, and to an optional 15-pin D-Sub connector for off-panel wiring, such as remote or back seat headset jacks or stick-mounted switches.

Up to ten audio channels are directly supported on the 50-pin connector, with an additional one supported on the optional 15-pin connector. Expansion of audio channels may be supported by externally busing or daisy-chaining audio connections.

Four audio channels are provided with on-board series resistors, allowing direct connection to low-impedance audio sources such as some VHF Comms and external music inputs. One audio channel supports a volume control to simplify the connection to sources that do not allow audio level control, such as some EFIS systems or engine monitors. The resistors and volume control are normally bypassed, and are enabled by cutting jumpers on the bottom of the circuit board.

All audio connections have two grounds associated with them-- which may be connected to cable shields and signal grounds, as required. Controls such as push-to-transmit signals each have one associated ground. This plethora of grounds greatly simplifies the wiring of any required shielded cable.

The AMX-1 may be airframe mounted, or mounted to the back of the intercom housing using stand-offs. To mount it to the intercom, the intercom must be disassembled and the case drilled for four 4-40 screws.

3. Pin Descriptions

AMX-1A J1 Intercom Connector Pin Assignments			
Pin Name	Pin Number	Function	Description
Pilot Mic	1	Pilot mic input	Pilot headset microphone input.
Pilot Transmit Key	2	Pilot push to transmit input	Pilot PTT control input. Active low (switch to ground)
Headphones	3	Common headphone audio bus	Common connection to all audio sources (excluding microphones) and headphones.
Gnd	4	Main electrical and signal ground	Power and signal ground.
Radio Transmit Key	5	Radio transmit control input	Controls the transmit mode of the VHF Comm radio. Active low (switch to ground).
Radio Mic	6	Radio microphone output	Radio transmit audio.
Pwr	7	Power input	Main intercom power input.
Pax 1 Mic	8	Passenger 1 mic input	Passenger microphone input for SPA-400 only. Not connected on Sport-200.
Pax 2 Mic	9	Radio microphone output	Passenger microphone input for SPA-400 only. Not connected on Sport-200.
Copilot Transmit Key	10	Copilot push to transmit control input	Copilot PTT control input. Active low (switch to ground).
Copilot Mic	11	Copilot mic input	Copilot headset microphone input.
Intercom Key	12	Intercom Key input	PTI control input for Sport-200 only. Not connected on SPA-400.

AMX-1A J2 Panel Connector Pin Assignments			
Pin Name	Pin Number	Function	Description
Radio Output	1	Radio receive audio	Audio connection from primary VHF Comm headphone output. Series resistor is available on this signal, see Section 6 for information. Internally connected to Aux HP (J2 pin 9).
Audio 2	2	Audio channel #2	Audio connection. Series resistor is available on this signal, see Section 6 for information.
Audio 3	3	Audio channel #3	Audio connection. Series resistor is available on this signal, see Section 6 for information.
Audio 4	4	Audio channel #4	Audio connection. Series resistor is available on this signal, see Section 6 for information.
Audio 5	5	Audio channel #5	Audio connection. Volume control available on this signal, see Section 6 for information.
Audio 6	6	Audio channel #6	Audio connection.
Audio 7	7	Audio channel #7	Audio connection.
Audio 8	8	Audio channel #8	Audio connection.
Aux HP	9	Auxiliary Headphone	Connect to auxiliary headphone jack. Internally connected to Radio Output (J2 pin 1).
Pilot Mic	10	Pilot microphone input	Connect to pilot microphone jack.
Pilot Transmit Key	11	Pilot push to transmit key input	Connect to pilot PTT switch (switch to ground).
Copilot Mic	12	Copilot microphone input	Connect to copilot microphone jack.
Copilot Transmit Key	13	Copilot push to transmit key input	Connect to copilot PTT switch (switch to ground).
Radio Mic	14	Radio microphone output	Connect to VHF Comm microphone input(s).
Radio Transmit Key	15	Radio transmit key output	Connect to VHF Comm transmit key. Internally connected to Aux Transmit Key (J2 pin 32).
Aux Mic	16	Auxiliary microphone input	Connect to auxiliary microphone. Used for backup in the event of an intercom failure. May also be used to drive a second VHF Comm microphone input. Internally connected to the Radio Mic signal (J2 pin 12).
Pwr	17	Intercom and headset power	Connect to system power bus through maximum 2A fuse. Power is also connected to J3 pin 15 in order to allow for remote ENC headset power.

Intercom Key A	28	Push to Intercom Key input	Connect to pilot PTI switch (switch to ground). Internally connected to J2 pin 30.
Intercom Key B	30	Push to Intercom Key input	Connect to copilot PTI switch (switch to ground). Internally connected to J2 pin 28.
Aux Transmit Key	32	Auxiliary Push to Transmit Key input	Connect to auxiliary PTT switch (switch to ground). Internally connected to Radio Transmit Key (J2 pin 15).
Gnda	18-27, 29, 31, 33-49	Signal grounds	Connect to wiring signal grounds and shield grounds as required. All Gnda pins are internally connected.
Gnda	50	Power ground	Connect to main system ground. Internally connected to all other Gnda pins.

AMX-1A J3 Off-Panel Connector Pin Assignments

Pin Name	Pin Number	Function	Description
Mic A	1	Microphone input	Selectable as Pilot Mic or Pax 1 Mic (SPA-400 only). See Section 6 for information on selecting modes.
Key A	10	Transmit or Intercom Key input	Selectable as Pilot Transmit Key or Intercom Key (Sport-200 only). See Section 6 for information on selecting modes.
Mic B	11	Microphone input	Selectable as Copilot Mic or Pax 2 Mic (SPA-400 only). See Section 6 for information on selecting modes.
Key B	5	Transmit or Intercom Key input	Selectable as Copilot Transmit Key or Intercom Key (Sport-200 only). See Section 6 for information on selecting modes.
Headphones	6	Headphone audio	Audio to headphones. May be daisy-chained or bused to all off-panel headphones.
Pwr	15	Power output for ENC headsets	Power feed for electronic noise cancelling headsets.
Gnda	2, 3, 4, 7, 8, 9, 12, 13, 14	Signal grounds	Connect to signal grounds and shield grounds as required. All Gnda pins are internally connected.

4. Electrical Characteristics Over Specified Operating Temperature

Parameter	Symbol	Value	Units	Conditions
Power Input	V_{CC}			Limited by intercom system and headset requirements.
Ambient Operating Temperature	T_A	-20 to +55	°C	Non-Condensing
Storage Temperature	T_S	-20 to +85	°C	Non-Condensing

5. Installation

Note: it is good practice to use thread locker liquid on all mounting screws to ensure long-term fastener integrity.

The AMX-1A audio bus device is designed to mount to the airframe or to the intercom cabinet using the supplied stand-offs and 4-40 mounting hardware.

For new installations, mount the device close enough to the intercom to allow the intercom cable to plug directly into the board. Using the supplied hardware, mount the device securely in position. In some installations, it may be necessary to build an extension cable (parts not supplied).

Mating 15-pin and 50-pin D-Sub connectors, back shells, box connectors and pins are available from suppliers such as Digi-Key (www.digi-key.com). The AMX-1A device design does not allow a back shell to be used for the mating connector to J2. After wiring is complete, simply tie-wrap the wires into the aircraft wiring harness.

The device provides many common ground signals in order to facilitate system wiring. In many cases, not all ground connections are required. It is the installer's responsibility to determine system grounding and shielding requirements.

6. Application Information

Refer to figure Figure 6-1 and Section 10 schematic for more information on configuring device options. Sections 11 and 12 show generic 4-place and 2-place installations.

Using the On-board Series Resistors

The Radio Output channel and Audio channels 2, 3 and 4 support series resistors.

Some audio sources, such as VHF Comms and other audio sources may require a series resistor for the intercom to operate properly. If you experience a situation where the audio levels in the system drop to a low level except from one source, then that source needs to use a series resistor. If more than one source requires series resistor, it may be necessary to disconnect, power off or unplug all audio sources and add them in one at a time to determine which of them should use series resistors.

To insert a resistor into the circuit, it is necessary to cut a jumper trace on the bottom side of the circuit board immediately underneath the jumper selector (X9, X10, X11 or X12) for that channel. Use a sharp knife or rotary cutting tool, as required.

Using the On-board Audio Level Adjustment

Audio channel 5 has a 100 KOhm variable resistor for volume control. It may be varied to adjust the audio level from devices that have no internal volume control capability.

In some cases, setting the volume control near its maximum level will affect the volume of other sources in the aircraft. It is important to test the audio level of all devices after an adjustment has been made. To insert the volume control in series with a source, cut the trace connecting the jumper selector X13 on the bottom side of the circuit board.

Modifications for SPA-400 and Sport-200 Applications.

The AMX-1A device comes preconfigured for Sport-200 or two-place SPA-400 intercom applications. In most 2-place installations, no further jumper modifications are required.

If an SPA-400 intercom is used, and if the two passenger microphone channels are required, and the optional Off-Panel Headset Connector Option is provided (J3), then it will be necessary to change the default jumpers X1-X4 on the circuit board.

The modification required is to cut the two jumper traces on the bottom side of the board that connect both X1 and X3, and solder in wire links in the X2 and X4 positions. Use a sharp knife or rotary cutting tool to make the cuts. Use stiff wire for the links.

Table 1 Two-Place or Four-Place Operating Mode

Mode	X1	X2	X3	X4	Function
SPA-400 two-place or Sport-200					Mic A = Pilot Mic; Mic B = Copilot Mic
SPA-400 four-place					Mic A = Pax 1 Mic; Mic B = Pax 2 Mic

Modifications for Sport-200 Intercom Key Applications.

Transmit Key on Pilot and/or Copilot Channels

If the intercom key is required for noisy cockpit applications of the Sport-200 *and* if the optional Off-Panel Headset Connector Option is used (J3), *then* it is possible to program J3 to pass the Intercom Key signals in place of Transmit Key signals. This allows the support both pilot and copilot remote headsets with remote intercom keying. Transmit keys would then be connected to J2, the Main Panel Connector.

To select this mode, cut the two signals underneath the board across X5 and X7 and solder in wire links in the X6 and X8 positions.

Ensure that jumpers X1 and X3 are also installed (or the jumper traces are not cut) to enable pilot and copilot audio on J3.

Transmit and Intercom Keys on Copilot Channel

Since most noisy environments are open-cockpit tandem-configuration aircraft, J3 can be use to connect the copilot audio and both Transmit Key and Intercom Key signals for the copilot only. In this mode, all pilot key signals are connected to J2, the Main Panel Connector. On J3, Pilot audio is still active, however, no pilot key signals are provided in this mode.

To select this mode of operation, cut the jumper trace across X7 and solder in a wire link in the X8 position. *J3 Key A* is then used for the copilot Intercom Key and *J3-Key B* is used for the copilot Transmit Key.

Table 2 Transmit Key and Intercom Key Jumper Selection

Mode	X5	X6	X7	X8	Function
Remote Transmit Keys					Key A = pilot transmit key; Key B = copilot transmit key
Remote Intercom Keys					Key A = intercom key; Key B = intercom key
Remote Dual Keys (Copilot only)					Key A= intercom key, Key B = copilot transmit key

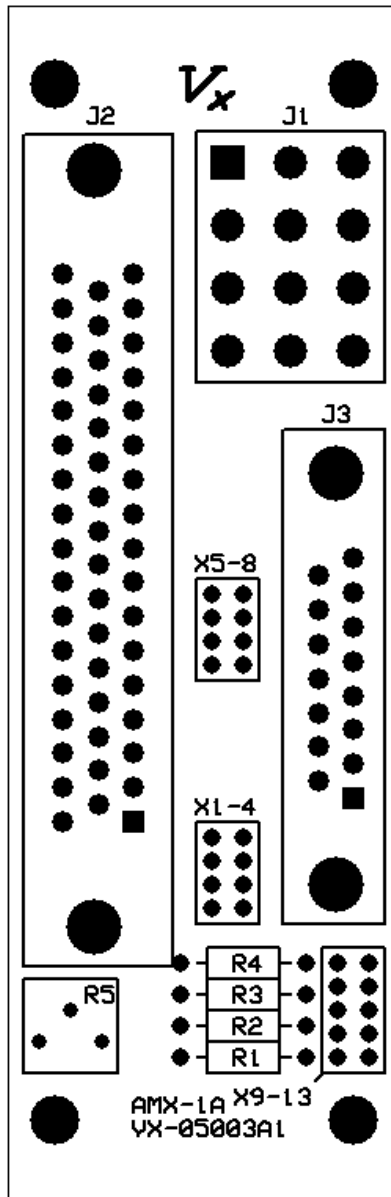

Figure 6-1. Outline View

7. Ordering Information

Part Number	Description
AMX-1A VX-05003xx-1	AMX-1A with optional 15-pin D-Sub off-panel connector.

8. Warranty and Support

This product is warranted for a period of two years after date of purchase against defects in materials or workmanship. Warranty returns will be replaced with new or refurbished product at the sole discretion of Vx Aviation. Customers shall be responsible for the shipping costs of both the returned and replacement product. Under no circumstances shall Vx Aviation be responsible for damages of any kind whatsoever resulting from the use of Vx Aviation products. Total liability is limited to the purchase price of the product. Customers take sole responsibility for fitness of use, application and installation of the product. As a condition of purchase, the customer shall accept complete liability for the product and its use.

For product inquiries and support, contact Vx Aviation.

© 2005, Vx Aviation. All rights reserved. Vx Aviation, Avismo and the bird logo are trademarks of Vx Aviation & Industrial Products. SPA-400 and Sport-200 are trademarks of Sigtronics Corporation.

9. Document Revision History

Issue Number	Date	Purpose
VXD-0503001A1	March 18, 2005	Initial Release reflecting A1 PCB design.
VXD-0503001A2	March 29, 2005	Updated to include product photo.
VXD-0503001A3	December 9, 2005	Updated web link and ordering options.



10. Device Schematic

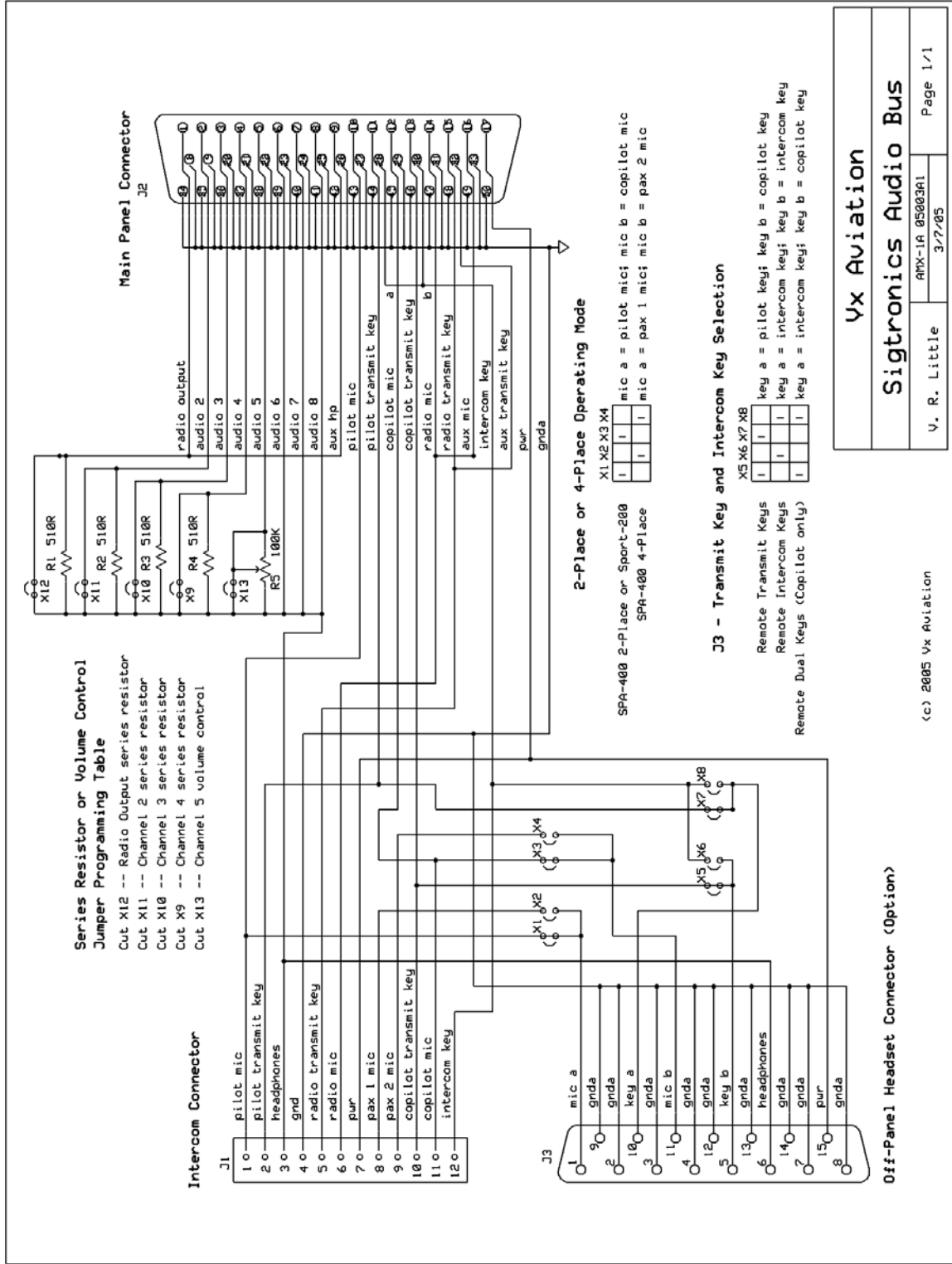

11. Typical 4-Place Installation

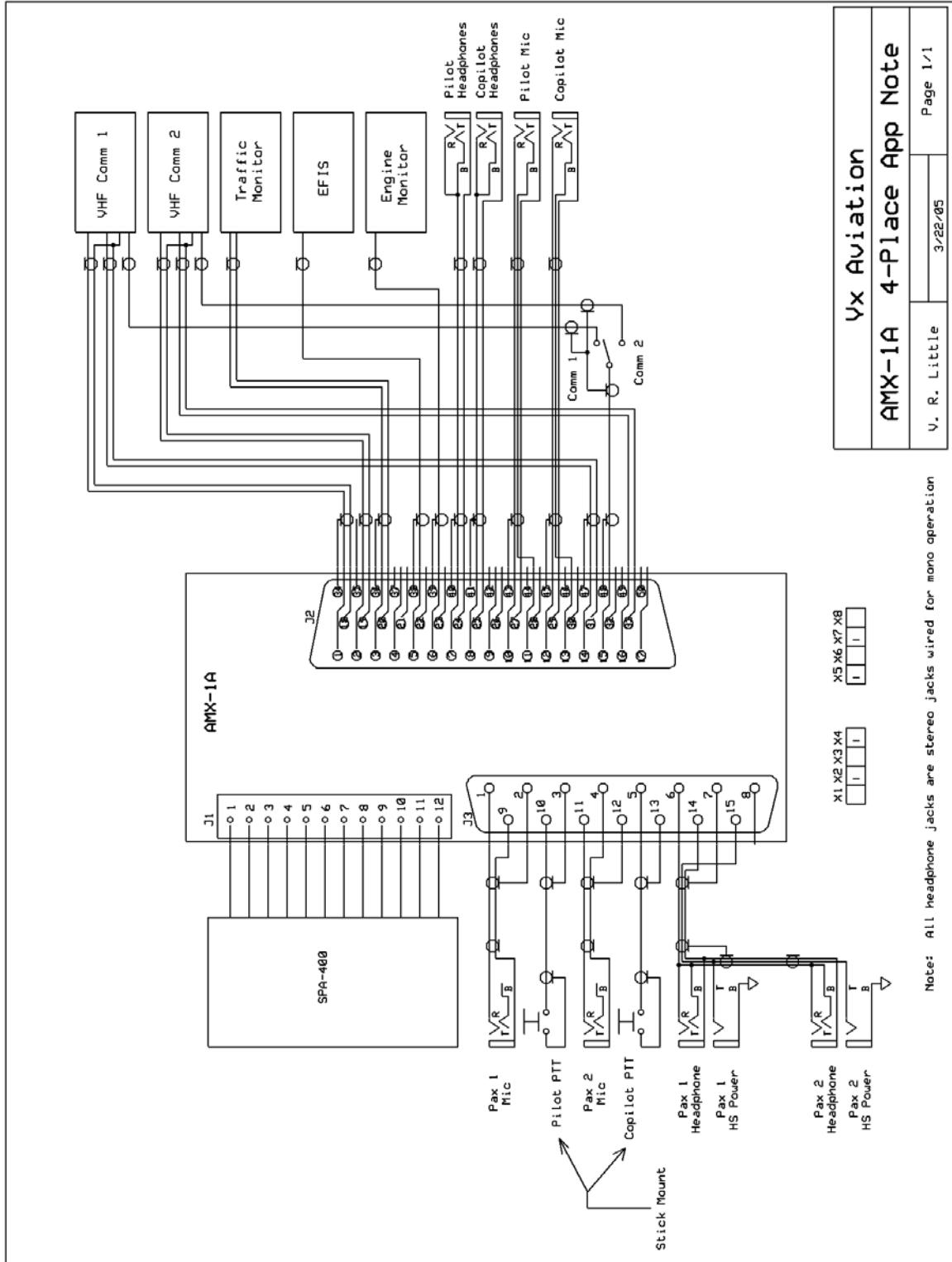

Vx Aviation
AMX-1A 4-Place App Note
 V. R. Little
 3/22/05
 Page 1/1

Note: All headphone jacks are stereo jacks wired for mono operation

12. Typical 2-Place Installation

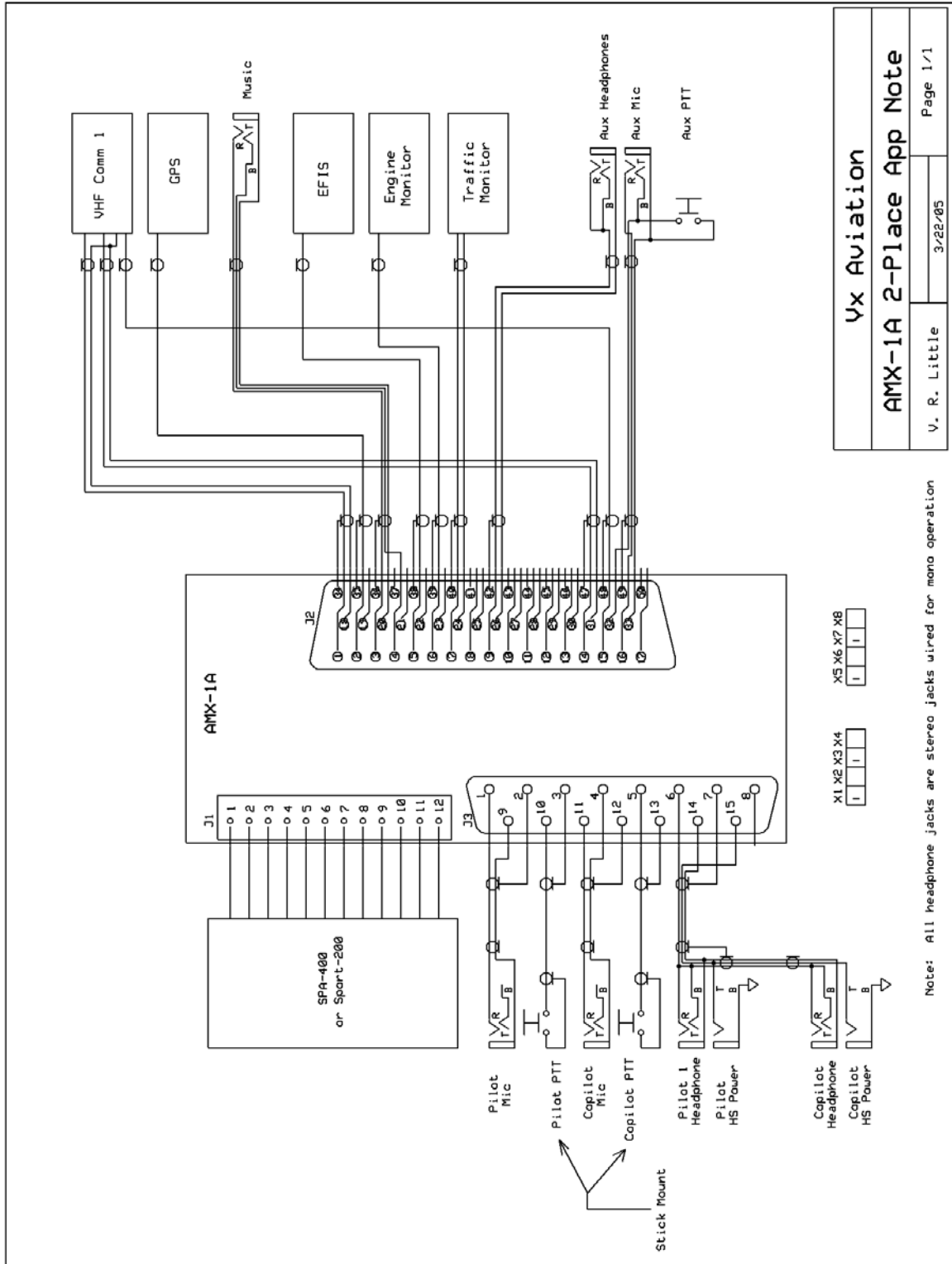

Vx Aviation	
AMX-1A 2-Place App Note	
V. R. Little	3/22/05
Page 1/1	