



Vx Aviation

AXIS™ FAMILY

*AXIS-9A EFIS Wiring Hub
AXIS-15A EFIS Wiring Hub
AXIS-25A EFIS Wiring Hub
GBX-25A Ground Bus Expander*

Avionics X-Connect
Interconnect System

Installation Guide

Ver. B1

(c) 2010, 2011 Vx Aviation



www.vx-aviation.com

AXIS™ Family Avionics X-Connect Interconnect System



Vx Aviation

AXIS™ Family

Description

The AXIS device family consists of the AXIS-9A, AXIS-15A and AXIS-25A wiring hubs, along with the GBX-25A bus distribution block. The AXIS devices are Electronic Flight Instrument Systems (EFIS) wiring hub devices that simplifies interconnect between EFIS and other avionics instruments using low-cost, easily available D-subminiature connectors and cables.

These devices provide simple, reliable interconnect that can be easily modified as avionics instruments are added or features change. No cutting and splicing is required to make these changes, thus improving system reliability and eliminating the cost of splices or wiring blocks. Labor and material costs for wiring harnesses is greatly reduced by centralization of the primary interconnect.

Each of the AXIS devices provide a backplane of five connectors that allow the distribution of common signals from EFIS systems to multiple instruments.

The AXIS-9A provides five DE-9 male connectors and is directly compatible with Dynon SkyView Network (SVN) cables. It eliminates the requirements for several SVN splitters and gender changers.

The AXIS-15A provides five DA-15 female connectors and is optimized for the distribution of RS-232 and other common signals between EFIS systems, avionics and instruments in a typical VFR panel.

In addition to the 15 bused connections, the AXIS-15A also provides two supplementary DA-15 female connectors and Fast-On tabs for the distribution of power or ground circuits.

The AXIS-25A is similar to the AXIS-15A, but provides five DB-25 female connectors that provide 25 bused signals. Separate GBX-25A devices provide the ground and power distribution, if required. In addition, two pins on the AXIS-25A bus may be assigned to power and ground, allowing for the future development of powered function modules that plug into the hub.

Finally, the GBX-25A device provides a convenient method of distributing multiple power or ground signals for low-power avionics devices. This device supplements the normal “forest of tabs” that is used for high power grounding applications. A single DB-25 female connector is provided, along with two Fast-On tabs for redundant main ground or power connection.

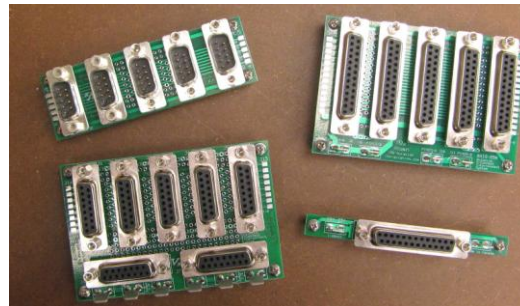

**Clockwise from top left: AXIS-9A,
AXIS-25A, AXIS-15A, GBX-25A**

Technical Summary (AXIS devices)

- ❑ Five backplane-connected D-Sub connectors
 - ❑ Functions as an RS-232 or similar signal splitter or as a SkyView Network splitter (AXIS-9A)
 - ❑ Works with all modern EFIS and avionics devices
 - ❑ Allows for multiple devices to connect to a single signal.
 - ❑ Facilitates changes and upgrades
 - ❑ Uses low-cost D-sub connectors
- ❑ On board prototyping area to allow simple circuits to be soldered in place, such as bias resistors, LED lamps or other useful functions (AXIS-15A, AXIS-25A)
- ❑ On board power/ground bus distribution (AXIS-15A)
- ❑ Mounting hardware included

Technical Summary (GBX-25A)

- ❑ Power/Ground bus distribution of up to 25 signals.
- ❑ Ideal for low-current avionics grounds or shielded wire terminations
- ❑ Redundant Fast-On terminals for main ground connections
- ❑ Mounting hardware included

NOT FOR USE IN CERTIFIED AIRCRAFT



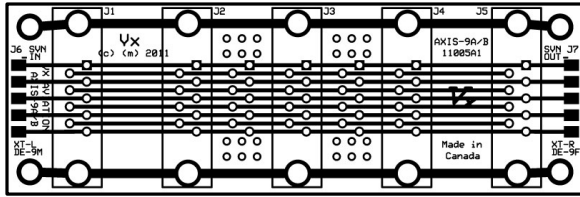

AXIS-9A

- Five x 9-pin male DE-9 Connectors
- Directly compatible with Dynon SkyView Network harnesses
- Expansion edge connector positions left and right (connectors optional)

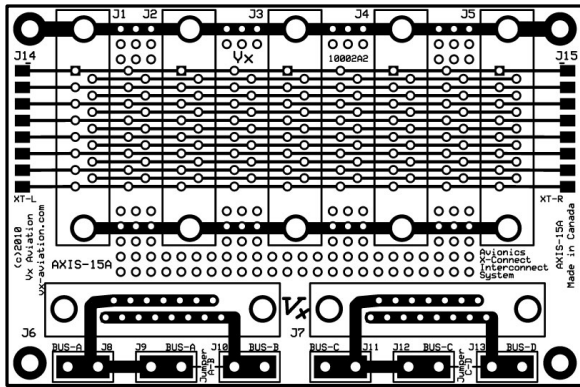
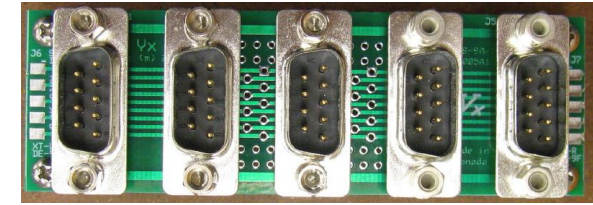

AXIS-15A

- Five x 15-pin female DA-15 Connectors (main bus)
- Two x 15-pin female DA-15 Connectors (power/ground distribution bus), split into two buses on each connector that may be jumpered together
- Ideal for distributing RS-232 and similar data signals throughout a typical VFR system
- Expansion edge connector positions left and right (connectors optional)

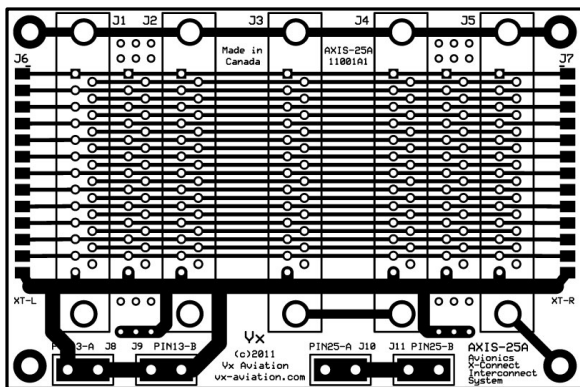
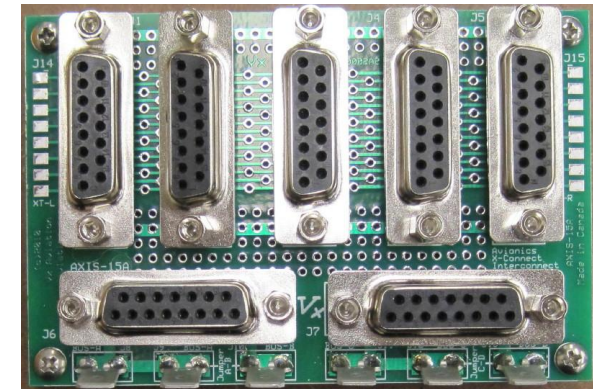

AXIS-25A

- Five x 25-pin female DB-25 Connectors (main bus)
- Ideal for distributing RS-232 and similar data signals throughout a typical IFR system.
- Expansion edge connector positions left and right (connectors optional)

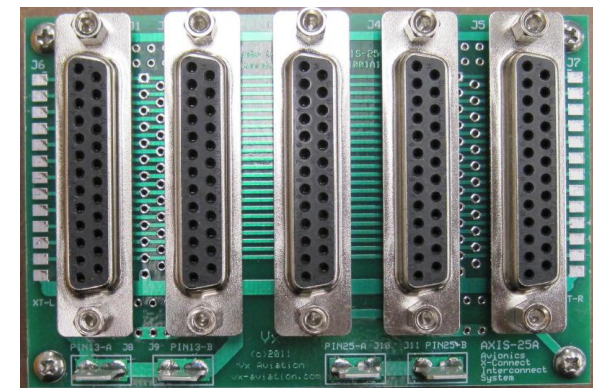

GBX-25A

- 25-pin female DB-25 Connector, plus two high-current Fast-On tabs for redundant power or ground connection
- Ideal for terminating conductor shield grounds

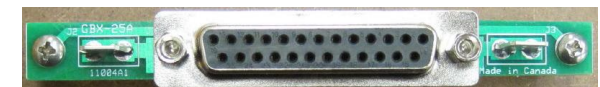

AXIS™ Family Avionics X-Connect Interconnect System



Vx Aviation

AXIS™ Family

AXIS Installation Notes

The following description is specific to the AXIS-15A wiring hub, but applies to the entire AXIS family. The AXIS-9A is specifically tuned for connecting the Dynon SkyView networks and uses male connectors. The AXIS-15 works well for distributing RS-232 signals and uses female connectors. The AXIS-25A is similar to the AXIS-15A but provides additional bused signals for more complex avionics panels and eliminates the power/ground distribution connectors.

AXIS-15A:

The five 15-pin connectors (J1-J5 in Figure 1) are wired as a backplane bus. Each pin of every connector is connected to its corresponding pin on all connectors. This allows any signal appearing on a pin to be replicated on the same pin on all connectors, thus allowing a fan-out of four loads with one signal.

The example shown in figures 2 and 3 illustrate how RS-232 signals are connected to multiple instruments. It also shows a unique aspect of the Dynon EFIS systems that connects all of the RS-232 transmitters and receivers between multiple EFIS devices together. This is accommodated with a

duplicate EFIS harness connected into any of the bus connector positions.

Other brands of EFIS systems do not have the capability of connecting RS-232 transmitters to each other, however, the receivers may be paired in the same fashion as the examples.

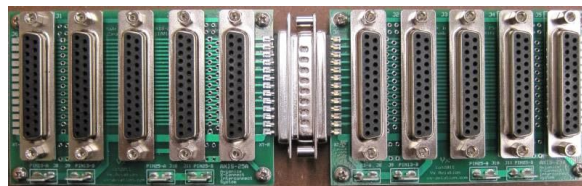

**Multi-board Expansion
(AXIS-25A Shown)**

Typically, multiple instruments are attached to a single connector. Additional connectors are required only when the capability of this connector is exhausted, such as when a signal must fan-out to multiple instruments. It is possible, however, to duplicate the same signal on one connector by soldering a jumper between the two corresponding pins using the holes provided between the bus connectors. For that matter, the same can be achieved by installing a jumper harness on one of the normal connector positions that will simply connect two bus pins together.

Positions J14 and J15 (also labeled as XT-L and XT-R) allow multiple boards to be connected

together by attaching solder-cup 15-pin Dsub connectors to the edges of the boards. One male and one female connector is required for each pair of boards. Mount the female connector to the XT-R position on the first board and the male connector to the XT-L position on the second board. Ensure that both boards are aligned properly by plugging them together before soldering these connectors in place. *Note: Version A1 of the AXIS-15A device does not support this feature, instead rows of holes are provided in these positions that may be used to connect multiple boards together with discrete wire jumpers.*

Two 15-pin connectors (J6, J7 in Figure 1) are wired to provide convenient ground or power distribution buses for up to 3A maximum loads on each pin. The bus on each connector is split into a 7-pin and an 8-pin bus that can be jumpered together using the fast-on connectors J9-J10 or J12-J13. This provides a great deal of flexibility, with up to 4 independent buses. The example shown in Figure 4 shows one example, with a single 15-pin ground bus, a 7-pin power bus and an 8-pin dimmer bus.

The Fast-On connectors are designed to carry large current loads and are used for the main ground or power connections.

For simple additional circuits, such as bias resistors, LEDs and so on, uncommitted component pads are provided in the board, along with access points for connector signals.



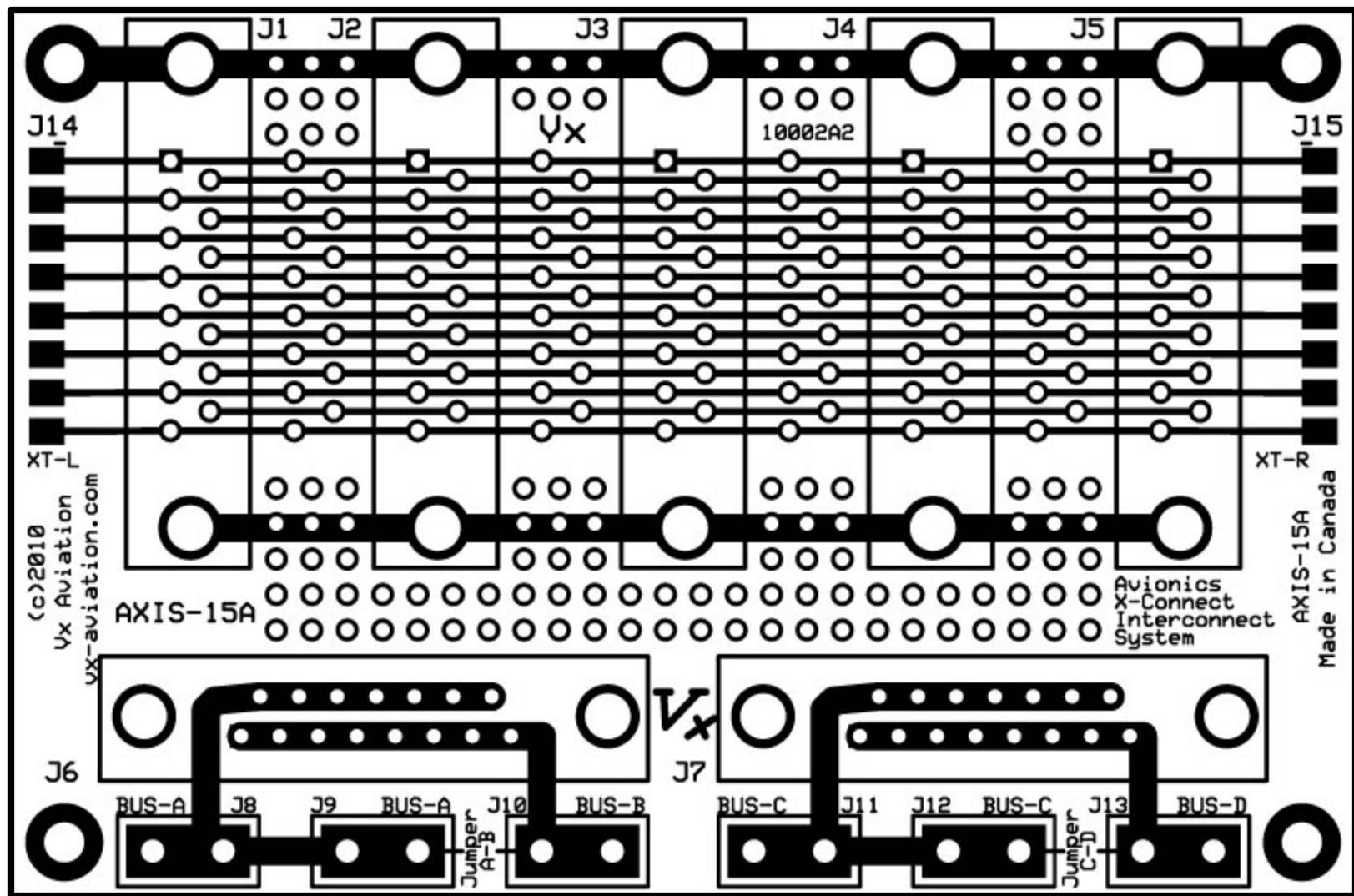
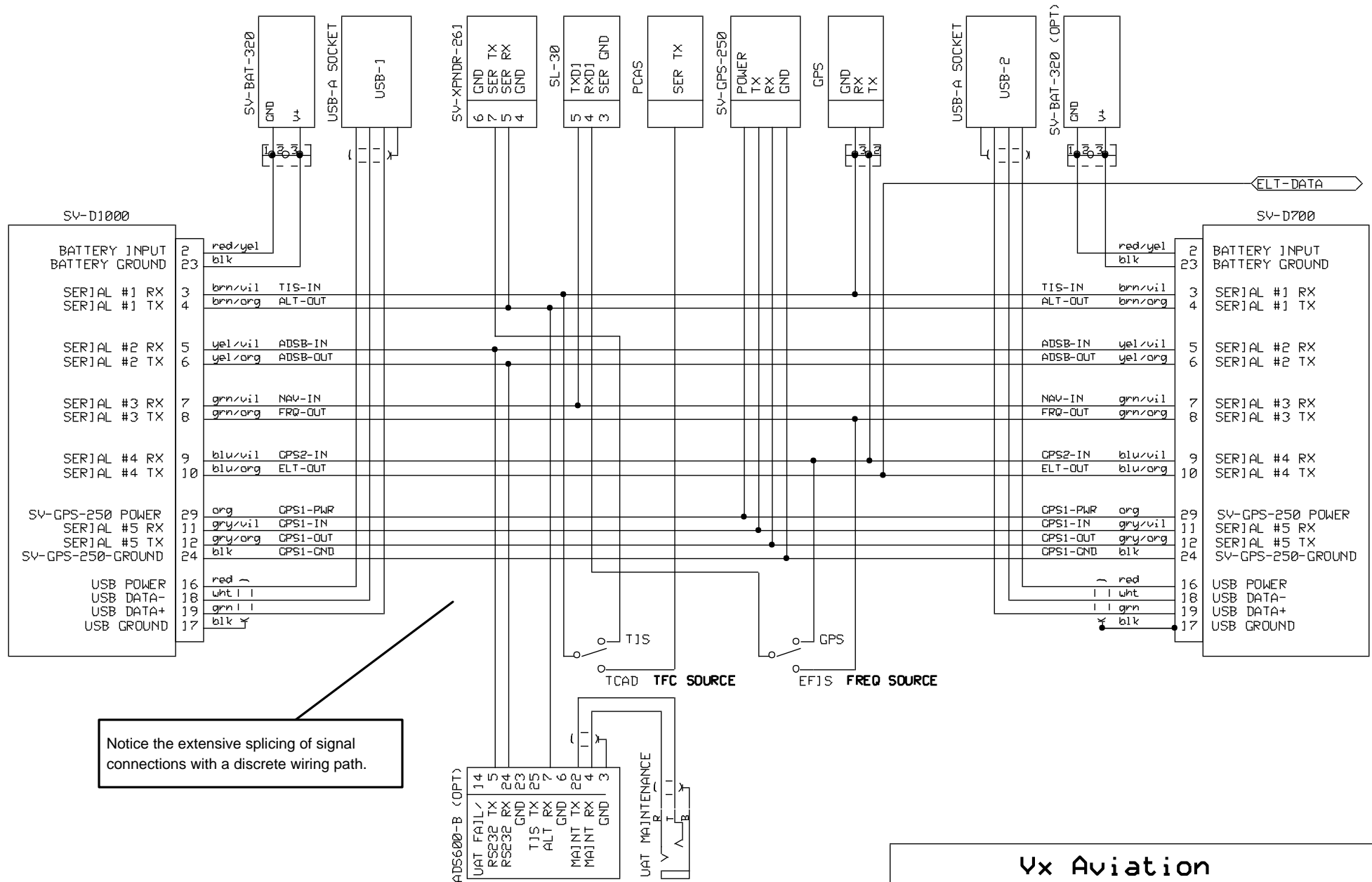

Figure 1. AXIS-15A Circuit Board Layout

- Connectors J1-J5 are bused for signal interconnect
- Connectors J6, J7 are bused for power and ground distribution
- J8, J10, J11, J13 are Fast-On connectors for power and ground connections
- J9, J12 are provided to facilitate jumpering between bus segments
- XT-L and JXT-R allows multi board expansion by attaching solder-cup Dsub-15 connectors to the board edges as required.
- Extra holes provided for signal access and small component mounting





Notice the extensive splicing of signal connections with a discrete wiring path.

Vx Aviation		
SkyView+Discrete Data Path		
V. R. Little		Installation Example

Figure 2. AXIS-15A Dual Dynon SkyView System, VFR, Discrete Data Path Wiring "Before"



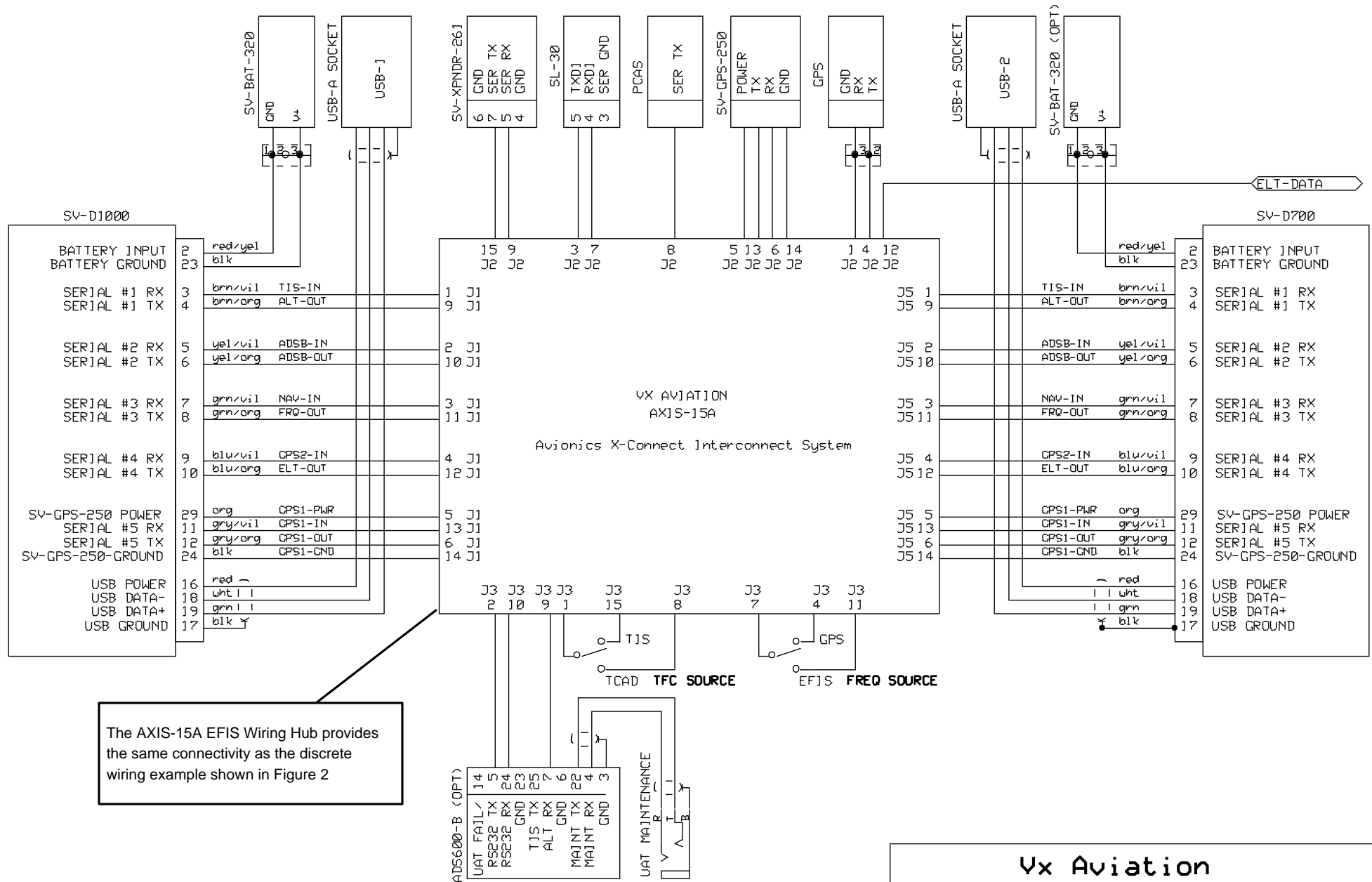

Figure 3. AXIS-15A Dual Dynon SkyView System, VFR, AXIS-15A Data Path Wiring "After"

Vx Aviation		
SkyView+AXIS-15A Data Path		
V. R. Little		Installation Example



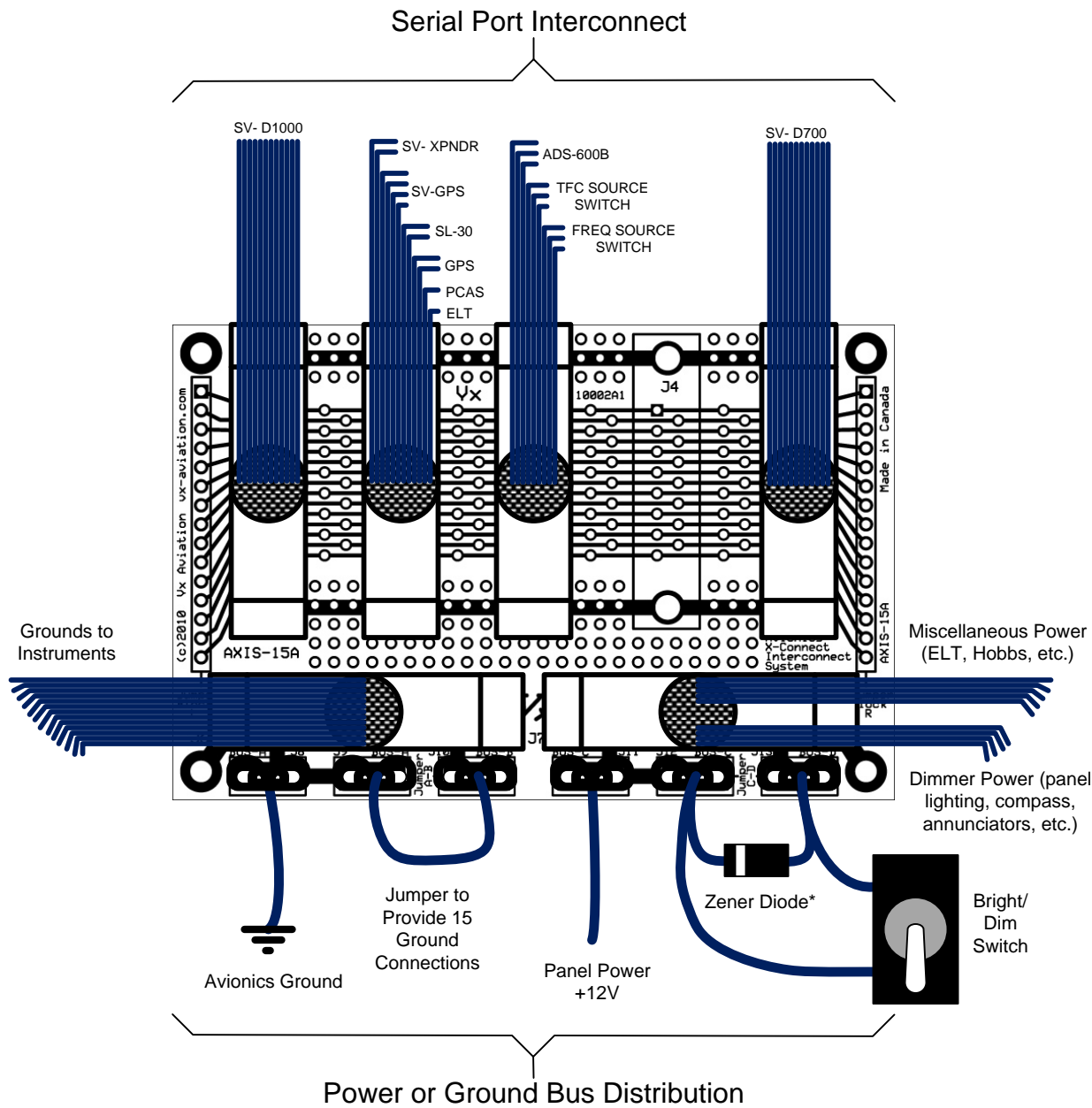

Figure 4.

AXIS 15A Wiring Pictorial for Dual Dynon SkyView System, VFR

Note the Ground Bus and the split Power/Dimmer bus.

* Zener Diode voltage sets minimum dimmer level.
5 Watt power rating recommended

