



Vx Aviation™

1160 Yew Ave

Blaine, WA 98230-9222

www.vx-aviation.com

Avismo™ Series Specification and Application Guide

RM-1B Wiring Harness Expander for the Rocky Mountain Micromonitor

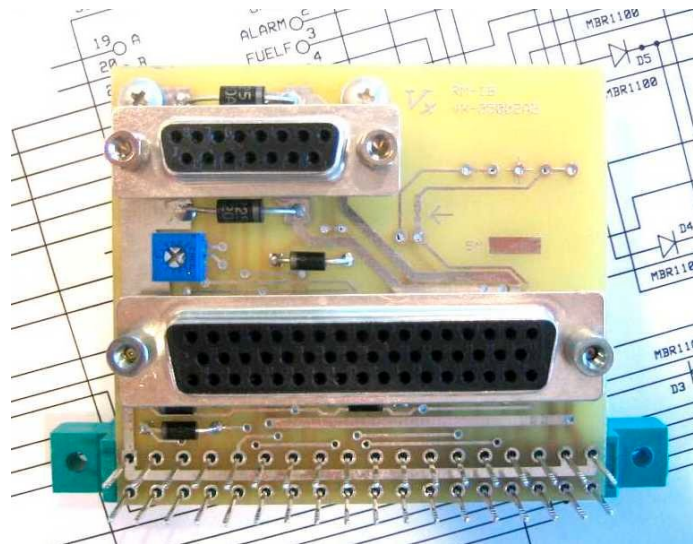

Figure 1-1. RM-1B Assembly

1. Features

- ❑ Simplifies the wiring harness for the Rocky Mountain (RMI) Micromonitor™ engine monitor system, including support for the serial data input and output option.
- ❑ Saves several hours of wiring time and increases system reliability.
- ❑ Provides over-voltage protection on primary power and backup power inputs.
- ❑ Adapts RMI 36 pin edge connector to a 50-pin D-Sub connector for firewall-forward connections and a 15-pin D-Sub connector for panel connections.
- ❑ Provides on-board volume control adjustment and an optional alarm sounder.
- ❑ Based on RMI installation manual application note.
- ❑ Small footprint of 2.8" x 2.5" (71.1 x 63.5 mm).

2. Description

The RM-1B is a wiring harness expander device that simplifies the connection of the RMI Micromonitor engine monitor to panel wiring and firewall forward wiring. It adapts the engine monitor 36 pin edge connector to a 50-pin D-Sub connector for firewall-forward wiring (sensors), and a 15-pin D-Sub connector to panel wiring.

On-board volume control allows the adjustment of audio levels without disassembly of the engine monitor. The optional on-board alarm buzzer eliminates the need to mount an external audible warning device.

The RM-1B device also provides transient voltage suppression diodes on both main power and backup up power inputs. This helps protect the engine monitor from voltage transients on the electrical buses.

The device mounts to the engine monitor in place of the original 36-pin edge connector. Two stand-offs are provided to support the circuit board. The assembly is mounted with 4-40 hardware through two holes drilled in the engine monitor tray.

Figure 2-1 shows a example of the difference between a hand-wired harness and the RM-1B wiring harness expander installed in an RV-9A aircraft.

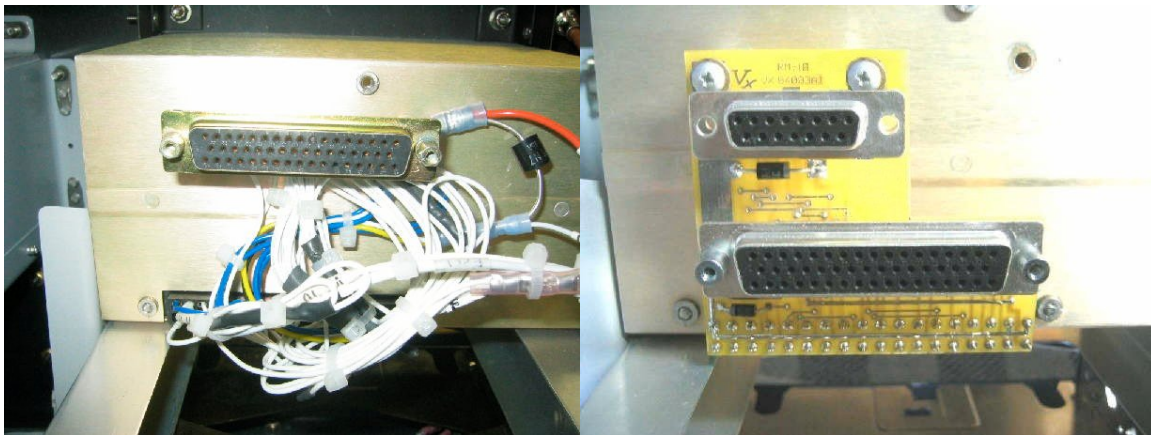

Figure 2-1. Conventional hand-wired harness (left) replaced with prototype RM-1B wiring harness expander (right).

3. Pin Descriptions

RM-1B J2 Engine Connector Pin Assignments					
J2 Pin Name	J2 Pin Number	J1 Connection	J3 Connection	Function	Description
Backup Power	1	U	5	In or Out	Backup Power source from redundant battery. May be connected on engine side (J2) or panel side (J3).
Fuel Flow	2	3		In	Input from fuel flow transducer.
10 Volts	3	16		Out	Sensor power output.
10 Volts	4	16		Out	Sensor power output.
10 Volts	5	16		Out	Sensor power output.
10 Volts	6	16		Out	Sensor power output.
10 Volts	7	16		Out	Sensor power output.
Tach/Mags	8	C	12	In or Out	Tachometer or magneto pulses from panel side or engine side. Connect one side only.
Oil Pressure	9	P		In	Input from oil pressure transducer.
Fuel Pressure	10	13		In	Input from fuel pressure transducer.
Carb Temp	11	S		In	Input from carburetor temperature sensor.

J2 Pin Name	J2 Pin Number	J1 Connection	J3 Connection	Function	Description
User Alarm #1	12	D	13	In	Alarm input. This signal is isolated from the engine monitor input by a Shottky diode and is also connected to the Alarm output of the engine monitor and to J3. The diode isolation allows the Alarm output to directly drive a lamp connected to +12V without overdriving the User Alarm #1 input. This allows critical alarm signals to directly drive a sounder or lamp, even if the engine monitor is turned off.
User Alarm #2	13	5	3	In	Alarm input. Input is isolated from the engine monitor input by a Shottky diode and is connected to J3. This signal may also directly drive a lamp or sounder independently of the engine monitor.
User Alarm #3	14	E	7	In	Alarm input. Input is isolated from the engine monitor input by a Shottky diode and is connected to J3. This signal may also directly drive a lamp or sounder independently of the engine monitor.
EGT+	15	J		In	Input from EGT sensor.
CHT+	16	H		In	Input from CHT sensor.
Aircraft Ground	17	1,18	1, 2, 8	Ground	Aircraft Ground.
Shield	18	17	1, 2, 8	Ground	Shield Ground. Connect to Transducer/Sensor shield.
Shield/FF Gnd	19	17	1, 2, 8	Ground	Shield Ground. Connect to Fuel Flow Transducer shield.

J2 Pin Name	J2 Pin Number	J1 Connection	J3 Connection	Function	Description
Shield	20	17	1, 2, 8	Ground	Shield Ground. Connect to Transducer/Sensor shield.
Shield	21	17	1, 2, 8	Ground	Shield Ground. Connect to Transducer/Sensor shield.
Shield	22	17	1, 2, 8	Ground	Shield Ground. Connect to Transducer/Sensor shield.
Shield	23	17	1, 2, 8	Ground	Shield Ground. Connect to Transducer/Sensor shield.
Shield	24	17	1, 2, 8	Ground	Shield Ground. Connect to Transducer/Sensor shield.
Shield	25	17	1, 2, 8	Ground	Shield Ground. Connect to Transducer/Sensor shield.
Shield	26	17	1, 2, 8	Ground	Shield Ground. Connect to Transducer/Sensor shield.
Shield	27	17	1, 2, 8	Ground	Shield Ground. Connect to Transducer/Sensor shield.
Shield	28	17	1, 2, 8	Ground	Shield Ground. Connect to Transducer/Sensor shield.
Shield	29	17	1, 2, 8	Ground	Shield Ground. Connect to Transducer/Sensor shield.
Shield	30	17	1, 2, 8	Ground	Shield Ground. Connect to Transducer/Sensor shield.
Shield	31	17	1, 2, 8	Ground	Shield Ground. Connect to Transducer/Sensor shield.
Shield	32	17	1, 2, 8	Ground	Shield Ground. Connect to Transducer/Sensor shield.
Shield	33	17	1, 2, 8	Ground	Shield Ground. Connect to Transducer/Sensor shield.
5.12 Volts	34	T		Out	Voltage reference output to sensors.
Manifold Pressure	35	9		In	Manifold pressure sensor input.
Signal Ground	36	14		Ground	Sensor ground.
Oil Temp	37	11		In	Oil temperature sensor input.
Outside Air Temp	38	12		In	Outside air temperature sensor input.

J2 Pin Name	J2 Pin Number	J1 Connection	J3 Connection	Function	Description
Reserved	39	6	4	--	Reserved, do not connect.
Ammeter	40	10		In	Current sensor input.
Signal Ground	41	14		Ground	Sensor ground.
Signal Ground	42	14		Ground	Sensor ground.
Signal Ground	43	14		Ground	Sensor ground.
Signal Ground	44	14		Ground	Sensor ground.
Signal Ground	45	14		Ground	Sensor ground.
Spare	46	--	6	In/Out	Spare connection. Suggested use is to connect to an oil pressure switch for hour meter (Hobbs) operation.
Clock Power	47	15	15	In or Out	Clock power input, to be connected to the aircraft battery through a fusible link, or to a backup battery on panel side. If connected to aircraft battery, the J3 connector pin may be used to feed other clock-power circuits on the panel side of the aircraft.
EGT-	48	8		In	EGT sensor input.
CHT-	49	F		In	CHT sensor input.
Aircraft Power	50	V	4, 11	Power	Over voltage protected power output to firewall forward devices.

RM-1B J3 Panel Connector Pin Assignments

J3 Pin Name	J3 Pin Number	J1 Connection	J2 Connection	Function	Description
SGND1	1	1,18	17-33	Signal Ground 1	Signal ground. Connect to Serial Data Input cable shield
SGND1	2	1,18	17-33	Signal Ground 2	Signal ground. Connect to Serial Data Output cable shield
SF2	3	5	13	In or Out	Connected to the User

					Alarm #2 input of the engine monitor through an isolation diode. Connection may be made on panel side through J3 or engine side through J2.
RENBL	4	6	--	Reserved	Reserved, do not connect.
EXTBAT	5	U	1	In or Out	Connect to an auxiliary power source (battery). Connection may be made on panel side through J3, or engine side through J2. Connect one side only. This circuit is protected from over voltage similar to the POWER connection.
SPARE	6	--	46	In or Out	Unassigned. Suggested use is to connect to an oil pressure switch to operate an hour meter (Hobbs).
SF3	7	E	14	In or Out	Connected to the User Alarm #3 input of the engine monitor through an isolation diode. Connection may be made on panel side through J3 or engine side through J2.
GND	8	1,18	17-33	Ground	Electrical ground. Connect to aircraft ground. Internally connected to J3 pins 1 & 2.
SDO	9	M		Serial Data Output	RS-232 data output from Micromonitor.
SDI	10	L		Serial Data Input	RS-232 data input to Micromonitor.

J3 Pin Name	J3 Pin Number	J1 Connection	J2 Connection	Function	Description
POWER	11	V	50	Power	Connect to aircraft power through a maximum 7-amp circuit breaker or fuse. Internal protection diode may cause circuit breaker or fuse to blow if voltage exceeds the maximum specified. Power connection must be made on panel side through J3 due to properties of the internal protection diode, but the J2 connection can feed downstream devices, to a limit of 1 Amp.
TACH	12	C	8	In or Out	Tachometer input. Connection may be made on panel side through J3, or engine side through J2. Connect one side only.
ALARM	13	2	39, 12	In or Out	Engine monitor alarm output, also connected to the engine monitor User Alarm #1 input through an isolation diode, and to J2. This is designed as a 'fail-safe' alarm output, where the J2 User Alarm #1 signal can directly drive the alarm lamp or sounder without the engine monitor being functional. Suggested use is to connect to an oil pressure switch, regulator over-voltage output, or both. This function is active low.
AUDIO	14	4	--	Out	Headset audio output from the engine monitor. The audio level is set by R1 (on board) or the internal control in the engine monitor.

J3 Pin Name	J3 Pin Number	J1 Connection	J2 Connection	Function	Description
CLOCK	15	15	47	In or Out	Clock power input/output, normally connected to the aircraft battery via J2, or to a backup battery on panel side via J3. If connected to the aircraft battery via J2, this pin may be used to feed other clock-power circuits in the aircraft. A diode prevents reverse current flow into the aircraft battery. Protect any direct battery connections with a 1A fuse or 24 AWG fusible link.

4. Electrical Characteristics Over Specified Operating Temperature

Parameter	Symbol	Value	Units	Conditions
Power Input	V _{CC}	0 to 15	VDC	J3 POWER, EXTBAT or CLOCK pins; J2 Clock Power pin.
Ambient Operating Temperature	T _A	-20 to +55	°C	Non-Condensing
Storage Temperature	T _S	-20 to +85	°C	Non-Condensing

5. Installation

Note: it is good practice to use thread locker liquid on all mounting screws to ensure long-term fastener integrity.

The RM-1B is designed to replace the engine monitor's original 36-pin edge connector. Some assembly is required, including soldering. Use electronics grade solder and a pencil type soldering iron. Ensure that the engine monitor is removed from the tray during assembly.

Remove the original edge connector from the tray. It will no longer be needed. Mount the provided edge connector using the original screws. Temporarily install the engine monitor and ensure that it fully mates with the new edge connector. If not, add shim washers between the connector and the mounting lugs until the fit is adjusted. Remove the engine monitor.

By carefully measuring the circuit board assembly and the edge connector you just installed, mark the position of the two mounting holes on the tray. Referring to Figure 5-1, these holes are located on the top outside edges of the RM-1B and are 1.25" (32 mm) apart, at a position 2.00" (51 mm) up from and inset 0.10" (2.5 mm) from pin 1 of the edge connector. Drill them to 0.125" (3.2 mm) and deburr.

Attach the two stand-offs to the RM-1B with 4-40 screws and lock washers. One of the stand-offs connects the electrical ground bus to the mounting tray. Slide the assembly (with the D-Sub connectors facing out) onto the exposed pins of the edge connector. Ensure that all pins are positioned correctly. Using 4-40 screws and lock washers attach the assembly from the inside of the tray.

Level the assembly on the edge connector pins and solder one pin on each end to lock everything together. Complete the soldering of all pins and inspect for workmanship. Carefully clean the solder flux from the assembly using flux remover, lacquer thinner or MEK.

Mating 15-pin and 50-pin solder cup D-Sub connectors and back shells are available from suppliers such as Digi-Key (www.digi-key.com).

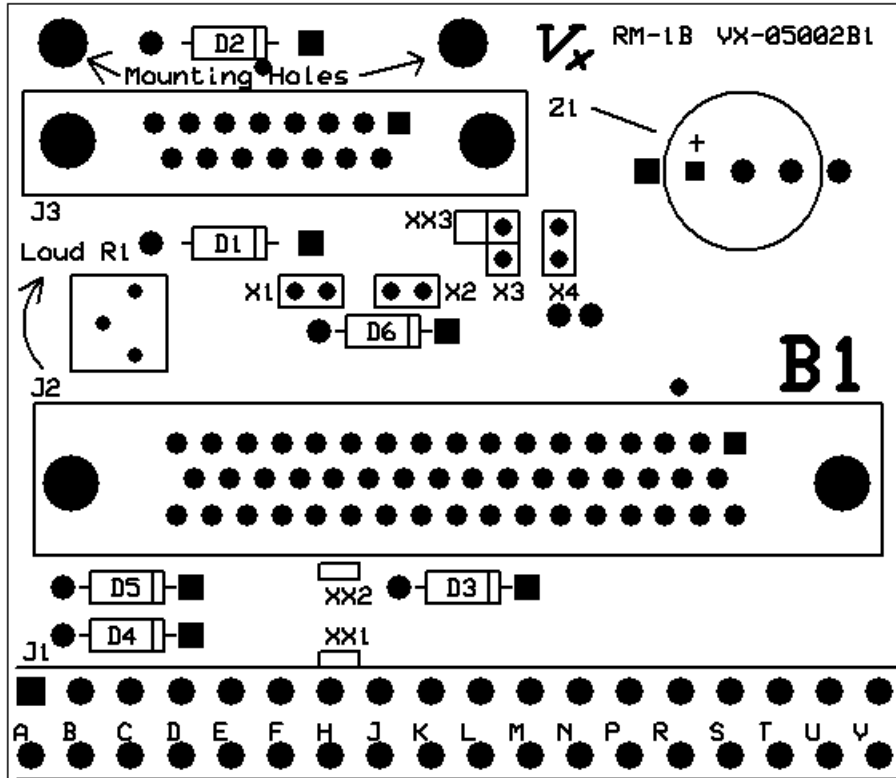

Figure 5-1. Outline View

6. Application Information

Overvoltage Protection

The RM-1B primary and backup power feed circuits have internal voltage clamping diodes, capable of protecting the engine monitor from certain types of transient voltage spikes on the power supply. Extended over-voltage may cause the power feed circuit breaker to trip or fuse to blow. If this occurs frequently, the integrity of the aircraft electrical system must be investigated. Under certain circumstances, the protection diodes will protect the engine monitor by developing a permanent short-circuit and must be replaced after the electrical system fault is corrected.

Using the On-board Audio Level Adjustment

In order for the audio level adjustment control to work, first it is necessary to set the audio level inside the Micromonitor engine monitor to its highest level. Refer to RMI's documentation to identify R50, the volume adjustment control, located inside the chassis. Once R50 is set, then the RM-1B on-board control may be used to easily control audio level without opening up the engine monitor box.

Using the On-board Piezo Buzzer (Option)

The on-board piezoelectric buzzer replaces the stock buzzer provided by RMI. It will sound whenever the Alarm output of the engine monitor is active. To reduce the audio level of the buzzer, it is acceptable to cover the hole in the buzzer with one or more layers of duct tape. It is also possible to disconnect it entirely by cutting the circuit trace adjacent to the buzzer (marked with an arrow on the circuit board adjacent to the buzzer).

Alarm Integration Time

The RMI Micromonitor can take up to six seconds to respond to a User Alarm (SFx) input condition. In applications where the alarm inputs drive both an external lamp as well as the Micromonitor, transient alarm conditions may illuminate the warning lamps briefly but not be detected by the Micromonitor. This is normal operation.

7. Ordering Information

Part Number	Description
RM-1B VX-05002xx-1-14	RM-1B 14 Volt operation, with buzzer.

8. Warranty and Support

This product is warranted for a period of two years after date of purchase against defects in materials or workmanship. Warranty returns will be replaced with new or refurbished product at the sole discretion of Vx Aviation. Customers shall be responsible for the shipping costs of both the returned and replacement product. Under no circumstances shall Vx Aviation be responsible for damages of any kind whatsoever resulting from the use of Vx Aviation products. Total liability is limited to the purchase price of the product. Customers take sole responsibility for fitness of use, application and installation of the product. As a condition of purchase, the customer shall accept complete liability for the product and its use.

© 2005, Vx Aviation. All rights reserved. Vx Aviation, Avismo and the bird logo are trademarks of Vx Aviation & Industrial Products. Micromonitor is a trademark of Rocky Mountain Instrument.

9. Document Revision History

Issue Number	Date	Purpose
VXD-0501001A1	January 13, 2005	Initial Release reflecting A1 proto PCB design.
VXD-0501001A2	January 23, 2005	Added mounting hole location data, updated source for mating connectors, corrected D-Sub call out, updated installation photo. Added volume control and piezo buzzer.
VXD-0501001A3	March 20, 2005	Updated product photo. Added fuse information to J3 CLOCK signal description. Editorial changes to reflect engine monitor product update.
VXD-0501001A4	March 30, 2005	Corrected J2 pin 4 descriptions.
VXD-0501001A5	October 2, 2005	Corrected: J3 pin5, J2 pin 1 both connect to J1 pin U (not J1 pin A).
VXD-0501001A6	December 9, 2005	Update web address.
VXD-0501001B1	December 1, 2006	Updated schematic and board design. J2 pin 39, J3 pin 4 connections changed to allow for future expansion. Buzzer now standard.



10. Device Schematic

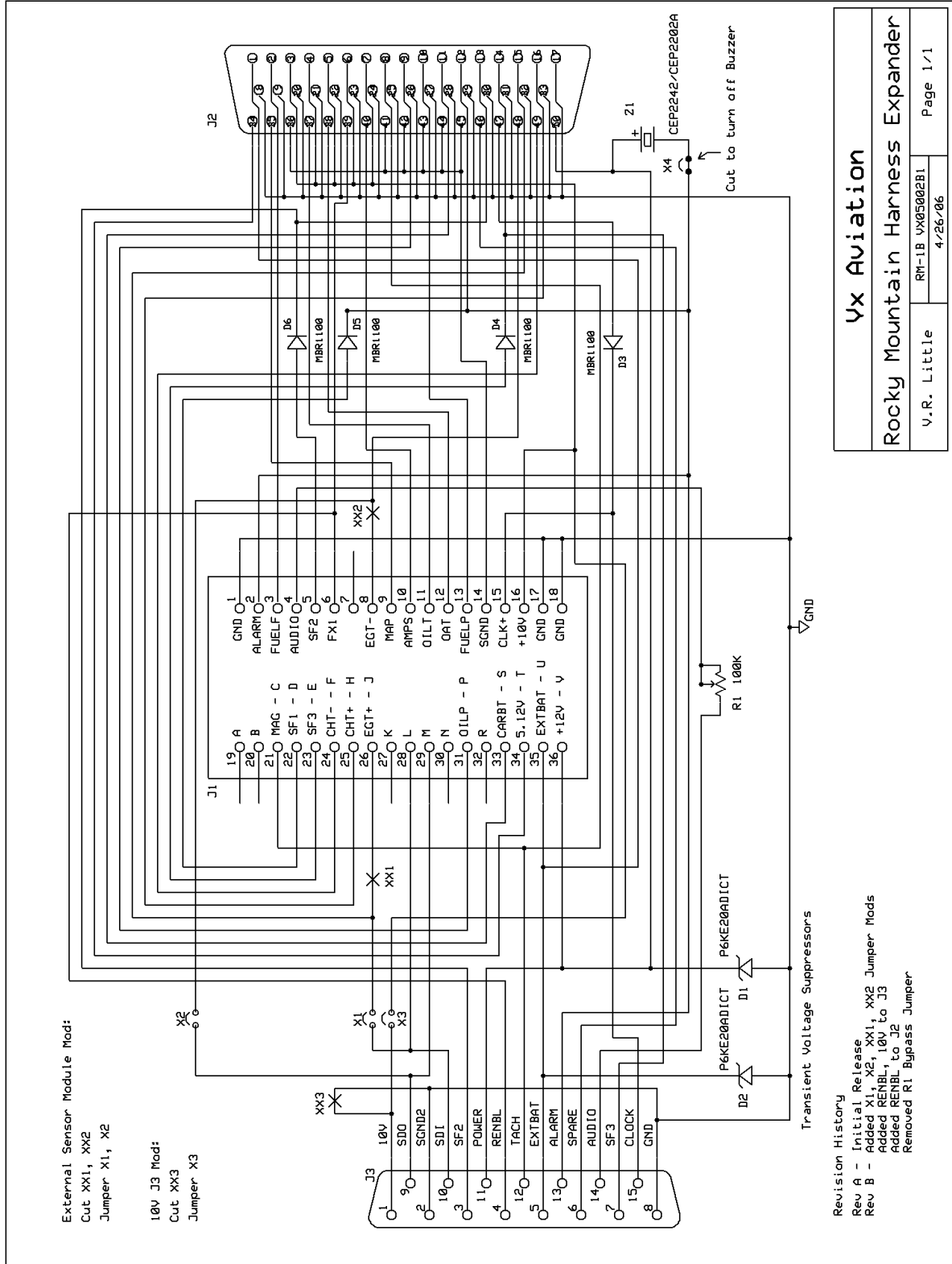

Vx Aviation	
Rocky Mountain Harness Expander	
V.R. Little	RH-1B Vx05002B1 4/26/06
Page 1/1	